



High Performance DC/DC
Converters for Harsh
Railway and Industrial
Environments

10- 40W Comprehensive Power Solutions for Railway Auxiliary Systems

URCD10U, URCD20U, URED40Uシリーズは、鉄道用途向けに設計されたシャーシマウント型およびDINレール型DC/DCコンバーターです。これらのコンバーターは、耐久性の高い機械設計と高度な機能により、鉄道車両搭載電子機器に関する EN50155規格、および耐衝撃・耐振動性に関する EN61373規格に準拠しています。

主な機能として、S2/S3電源遮断ソリューション、突入電流制限、逆極性保護、EN55032クラスA/B準拠のEMIフィルタリング、および内蔵ラインヒューズが挙げられます。これらの機能により、システム設計が容易になり、開発時間を抑えることができます。

14V~160Vdcの広い12:1入力電圧範囲により、単一モジュールで多様な電力システムに対応し、出力は、DC3.3V、5V、12V、15V、24V、±5V、±12V、±15Vに対応しています。また、過電流、短絡、過電圧、低電圧、過熱に対する保護機能を備えています。

URCD10U, URCD20U, URED40Uシリーズは、標高5000mまでの動作と、70℃を超える高温環境下でもフル負荷性能を維持できるよう設計されており、鉄道車両、線路脇などの厳しい環境条件に適応出来ます。

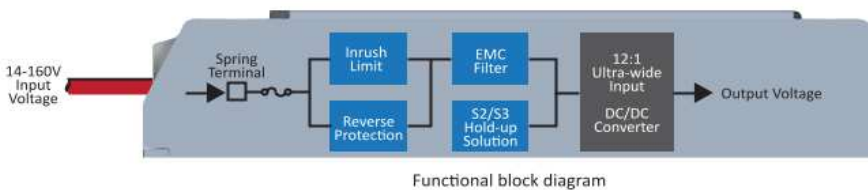

URCD10U Series
URCD20U Series
URED40U Series
DC/DC Converters

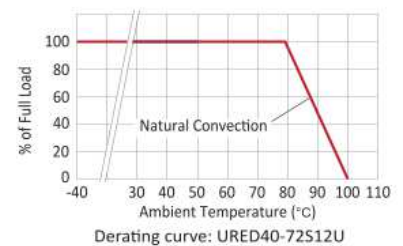

Features

- 10W、20W、40W出力
- 12:1広入力範囲：14-160Vdc
- 出力：3.3, 5, 12, 15, 24, ±5, ±12, ±15Vdc
- S2/S3電源遮断対応
- 突入電流制限、逆極性保護
- EMIフィルタ EN 55032 Class A/B準拠
- 内蔵ラインヒューズ
- EN 0155、EN61373、IEC/UL/EN 62368-1
- 5000m運用高度
- 3年製品保証

Applications

- 鉄道補助システム
- 鉄道車両電子機器
- 線路沿い監視機器
- 産業オートメーション制御
- 遠隔監視・通信システム

P-DUKE Technology Co., Ltd.
Tel: +886-4-2359-0668 | E-mail: sales@pduke.com | Web: www.pduke.com

www.pduke.com is the only official website of P-DUKE Technology. Please pay attention to unauthorized phishing websites and support the crackdown on counterfeit products. If you have any questions about whether the product is sold by a legitimate authorized dealer, please contact us to inquire about the authenticity of the product or authorization.

JEMCO 株式会社ジェムコ



大阪本社 TEL : 06-6338-8566
東京 TEL : 080-6449-9194
名古屋 TEL : 0587-96-1970

<https://www.jemc.co.jp/> e-mail: inf@jemc.co.jp



P-DUKE POWER

URED40U Series

Chassis-Mount DC-DC Converter
Up to 40 Watts

3
YEARS
WARRANTY

ROHS
COMPLIANT

REACH
COMPLIANT



Railway



Automation



Datacom



IPC



Industry



Measurement



Telecom



Automobile



Boat



Charger



Medical



PV



3000 VDC Isolation Voltage	12:1 Ultra-Wide Input Range	FUSE Installed	HOLD UP	INRUSH CURRENT LIMIT	Internal EN55032 Class A Filter	LOW Standby Power	NO Min. Load Required	Operating Altitude 5000 meter	REMOTE ON OFF	REVERSE POLARITY PROTECTION	OCP
OVP	SCP	UVP	OTP								

PART NUMBER STRUCTURE

URED40 -	72	S	05	U	-	H	DR
Series Name	Input Voltage (VDC)	Output Quantity	Output Voltage (VDC)	Input Range		Hold-up grade Options	Assembly Options
	72: 14.4~160	S: Single	05: 5 12: 12 15: 15 24: 24	12:1		□: S2 H: S3 N: Without Hold-up Function	□: None DR: Din Rail Mounting Type
		D: Dual	12: ±12 15: ±15				

TECHNICAL SPECIFICATION All specifications are typical at nominal input, full load and 25°C unless otherwise noted

Model Number	Input Range	Output Voltage	Output Current @Full Load	Input Current @No Load	Efficiency	Maximum Capacitor Load
	VDC	VDC	A	mA	%	µF
URED40-72S05U	14.4 ~ 160	5	8	20	87.5	12000
URED40-72S12U	14.4 ~ 160	12	3.33	15	90	2040
URED40-72S15U	14.4 ~ 160	15	2.67	15	90	1300
URED40-72S24U	14.4 ~ 160	24	1.67	15	90	500
URED40-72D12U	14.4 ~ 160	±12	±1.67	15	89	±980
URED40-72D15U	14.4 ~ 160	±15	±1.33	15	89	±640

INPUT SPECIFICATIONS

Parameter	Conditions	Min.	Typ.	Max.	Unit
Operating input voltage range	72Vin(nom)	14.4	72	160	VDC
Input fuse	Slow Blow 72Vin(nom)		6.3		A
In-rush current			15		A
Start up voltage	72Vin(nom)			14.4	VDC
Shutdown voltage	72Vin(nom)	10	11.5	13	VDC
Start up time	Constant resistive load Power up		90		ms
Input surge voltage	1 second, max. 72Vin(nom)			200	VDC
Interruption of power supply	EN50155 Class S2 EN50155 Class S3(Options)	10 20			ms
Remote ON/OFF	Referred to - Vin pin Positive logic DC-DC ON DC-DC OFF Input current of Ctrl pin Remote off input current	-0.5	Open or 3 ~ 12VDC Short or 0 ~ 1.2VDC 5	+1	mA mA

OUTPUT SPECIFICATIONS

Parameter	Conditions	Min.	Typ.	Max.	Unit
Voltage accuracy	Single Dual	-1.0 -1.2		+1.0 +1.0	%
Line regulation	Low Line to High Line at Full Load	-0.5		+0.5	%
Load regulation	No Load to Full Load	-1.5		+1.5	%
Cross regulation	Asymmetrical load 25%/100% FL	-1.0		+1.0	%
Voltage adjustability	Single output	-5.0		+5.0	%
Ripple and noise	Measured by 20MHz bandwidth				
	5Vout 12Vout, 15Vout 24Vout		75 100 150		mVp-p
Temperature coefficient		-0.02		+0.02	%/°C
Transient response recovery time	25% load step change		250		µs
Over voltage protection	Zener diode clamp		6.2 15 20 30		VDC
Output indicator			Green LED		
Over load protection	% of Iout rated; Hiccup mode		160		%
Short circuit protection			Continuous, automatics recovery		

GENERAL SPECIFICATIONS						
Parameter	Conditions		Min.	Typ.	Max.	Unit
Isolation voltage	1 minute	Input to Output Input (Output) to Case	3000 2250			VDC
Isolation resistance	500VDC		1			GΩ
Isolation capacitance				6000		pF
Switching frequency		5Vout Others	175 140	210 170	225 182	kHz
Safety meets						IEC/ EN/ UL62368-1
Standard approvals						EN50155 EN45545-2
Chassis material						Aluminum
Weight						173g(6.10oz)
MTBF	MIL-HDBK-217F, Full load					9.279 x 10 ⁵ hrs

ENVIRONMENTAL SPECIFICATIONS						
Parameter	Conditions		Min.	Typ.	Max.	Unit
Operating case temperature			-40		+100	°C
Maximum case temperature					100	°C
Over temperature protection				115		°C
Storage temperature range			-40		+105	°C
Operating altitude					5000	m
Thermal shock						MIL-STD-810F
Shock		□□□□□U □□□□□U - DR				EN61373, MIL-STD-810F EN61373, IEC60068-2-27
Vibration		□□□□□U □□□□□U - DR				EN61373, MIL-STD-810F EN61373, IEC60068-2-6
Relative humidity						5% to 95% RH

EMC SPECIFICATIONS			
Parameter	Conditions		Level
EMI	EN55032, EN50121-3-2	Conducted Emission Radiated Emission	Class A Class B
EMS	EN55035, EN50121-3-2		
ESD	EN61000-4-2	Air ± 8kV and Contact ± 6kV	Perf. Criteria A
Radiated immunity	EN61000-4-3	20V/m	Perf. Criteria A
Fast transient	EN61000-4-4	± 2kV	Perf. Criteria A
Surge	EN61000-4-5	EN55035:±1kV and EN50121-3-2:±2kV	Perf. Criteria A
Conducted immunity	EN61000-4-6	10Vr.m.s	Perf. Criteria A
Power frequency magnetic field	EN61000-4-8	100A/m continuous; 1000A/m 1 second	Perf. Criteria A

CHARACTERISTIC CURVE

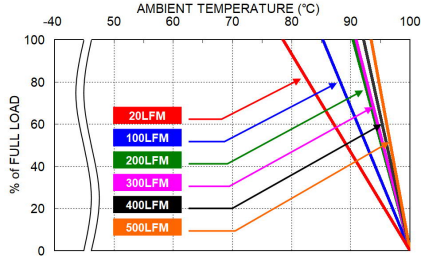

URED40-72S12U Derating Curve

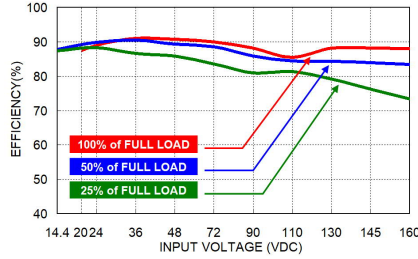

URED40-72S12U Efficiency vs. Input Voltage

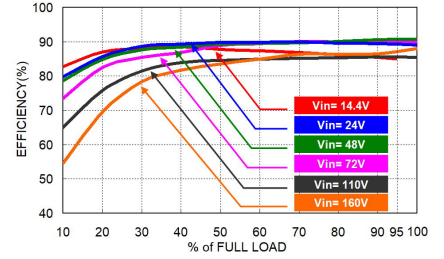

URED40-72S12U Efficiency vs. Output Load

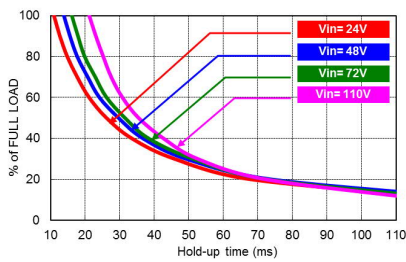

URED40-72S12U Hold-up Time Curve

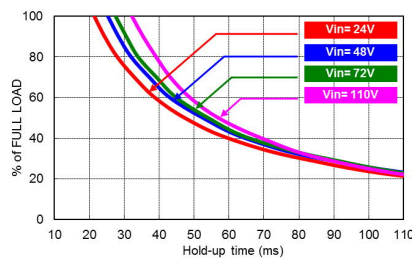

URED40-72S12U-H Hold-up Time Curve (Options)

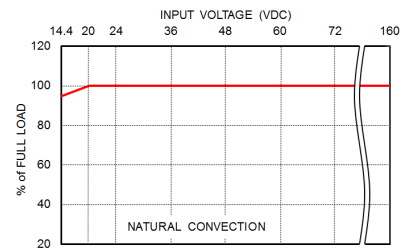

Derating Curve vs. Input Voltage

MECHANICAL DRAWING

CHASSIS MOUNTING TYPE

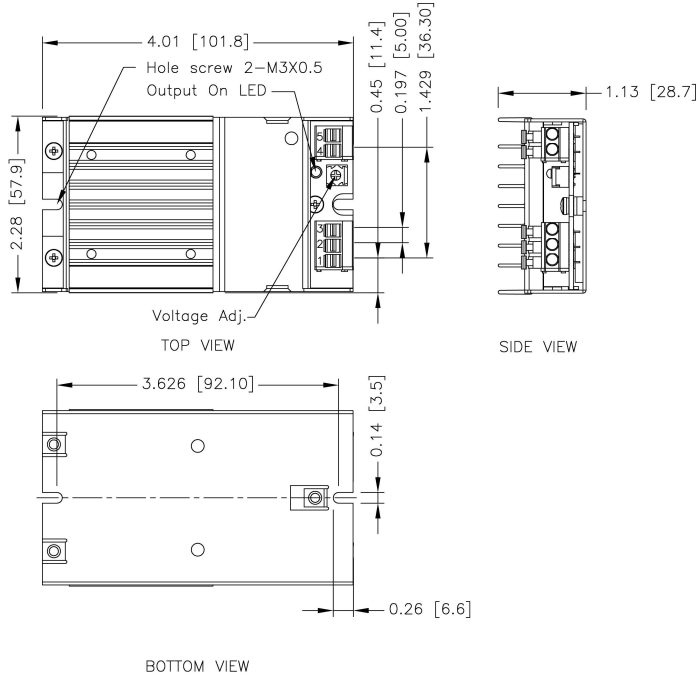

TERMINAL CONNECTION

NO.	SINGLE
1	+ Vin
2	- Vin
3	Ctrl
4	- Vout
5	+ Vout

※ Terminals – wire range from 14 to 20 AWG

- All dimensions in inch [mm]
Tolerance :x.xx±0.02 [x.x±0.5]
x.xxx±0.010 [x.xx±0.25]
- M3x0.5 screw locked torque MAX 5.0kgf-cm/0.49N-m

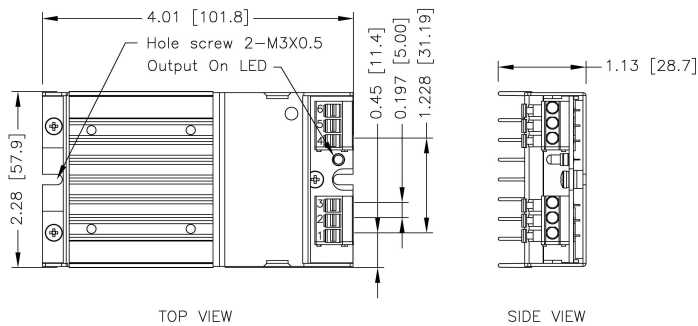

TERMINAL CONNECTION

NO.	DUAL
1	+ Vin
2	- Vin
3	Ctrl
4	- Vout
5	Com
6	+ Vout

※ Terminals – wire range from 14 to 20 AWG

- All dimensions in inch [mm]
Tolerance :x.xx±0.02 [x.x±0.5]
x.xxx±0.010 [x.xx±0.25]
- M3x0.5 screw locked torque MAX 5.0kgf-cm/0.49N-m

MECHANICAL DRAWING(CONTINUED)

DIN RAIL MOUNTING TYPE (OPTIONS)

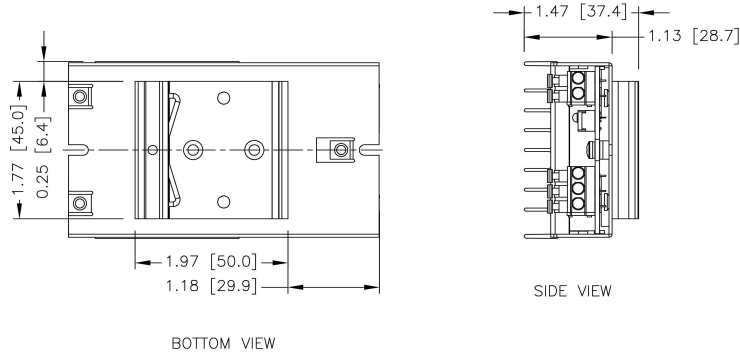

1. All dimensions in inch [mm]
Tolerance :x.xx±0.02 [x.x±0.5]
 x.xxx±0.010 [x.xx±0.25]
2. M3x0.5 screw locked torque MAX 5.0kgf-cm/0.49N-m

THERMAL CONSIDERATIONS

The power module operates in a variety of thermal environments. However, sufficient cooling should be provided to help ensure reliable operation of the unit. Heat is removed by conduction, convection, and radiation to the surrounding environment. Proper cooling can be verified by measuring the point as the figure below. The temperature at this location should not exceed "Maximum case temperature". When operating, adequate cooling must be provided to maintain the test point temperature at or below "Maximum case temperature". You can limit this temperature to a lower value for extremely high reliability.

